

ACER Group

Springwood Industrial, Inc.
1062 N. Kraemer Place
Anaheim, CA 92806
Tel: 714-632-9701 Fax: 714-632-9730
<http://www.acergroup.com>

info@acergroup.com

Klim Industrial, Inc.
244 N. Randolphville Road
Piscataway, NJ 08854
Tel: 732-752-9100 Fax: 732-752-9101
<http://www.acergroup.com>

acer_klim@yahoo.com

PROCEDURE TO SETUP AGS-1020AHD SURFACE GRINDER

1. Unwrap the machine and check out machine for any physical damage. If so, report to your dealer as soon as possible. Touch-up paint is inside the toolbox. Use it as needed.
2. Turn vertical handwheel clockwise (spindle up) to take out spindle support block (See figure on left). Move machine to appropriate location. Put 3 leveling screw, nut and pad on machine (See figure on right).

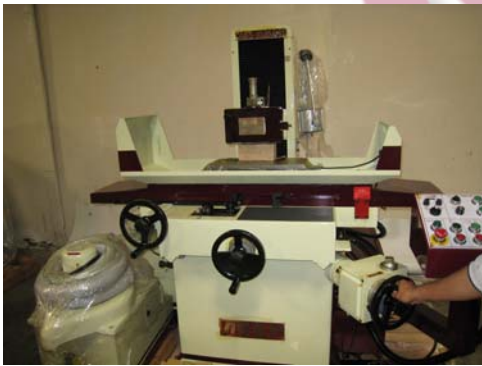

Remove the four brackets.



3. Check input power that will be used for the machine. Power required for our machines are: 230V three phase (3Φ) or 460V three phase (3Φ). Power must be first specified upon ordering. Please connect the power to R.S.T.G Ground terminal as follows with minimum current of 12 amps (230V).

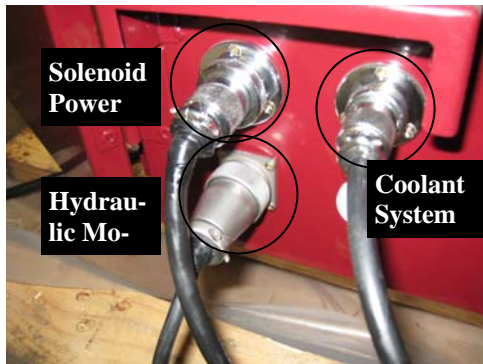

4. Hook up two electronic conduct connectors and wire, from hydraulic system, one from dust suction and coolant system.

5. Connect two corresponding hydraulic hoses: A-A, B-B, P-P, T-T as labeled.

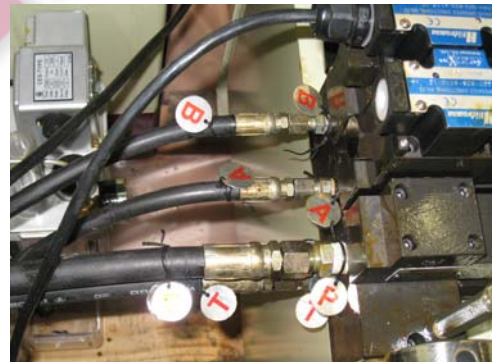

6. Fill up hydraulic oil Mobile DTE25 (minimum 30 gallons) and lubricating oil (See figure on left). Make sure filling gauge is at F. Fill up lube oil Vetra #2 way oil (see figure on right).



7. Turn on control. Make sure all the motors are running clockwise (spindle motor, hydraulic motor, cross-feed motor, vertical rapid motor, and coolant pump motor). 1) Turn on Main Power switch (See Fig. 1) Release emergency button. Then press the circuit power on. (See Fig. 2) 2) Turn on chuck control. Press spindle (See Fig. 3 & 4), hydraulic (See Fig. 4 & 5) and dust suction and coolant system buttons (See Fig. 6 & 7). to check rotation. 3) Check cross-feed motor by toggling in and out switch while function switch is in manual mode & surface grinding mode (See Fig. 8). 4) Check rapid vertical motor by pressing up and down push buttons while function switch is in rapid mode (See Fig. 9).

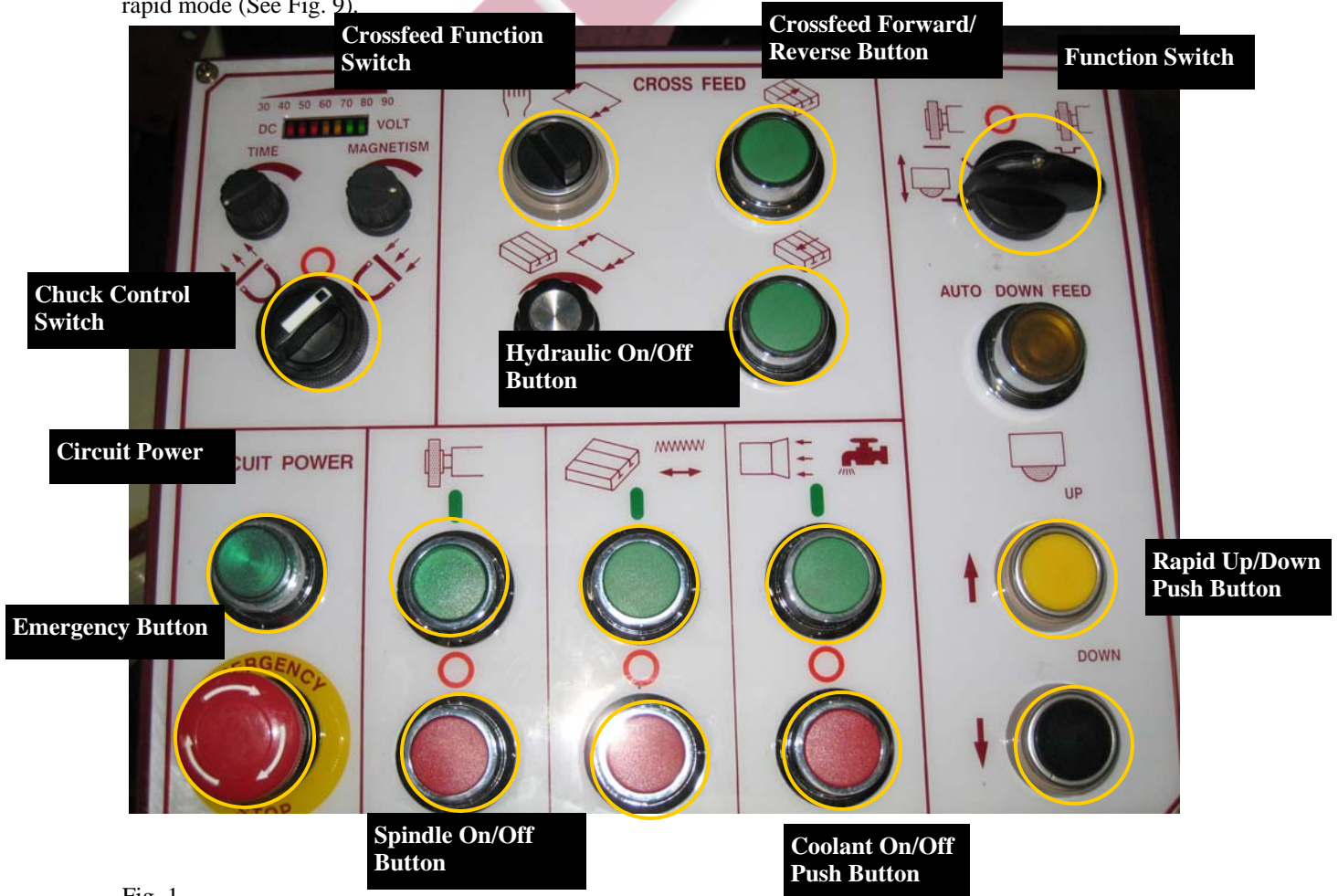

Fig. 1

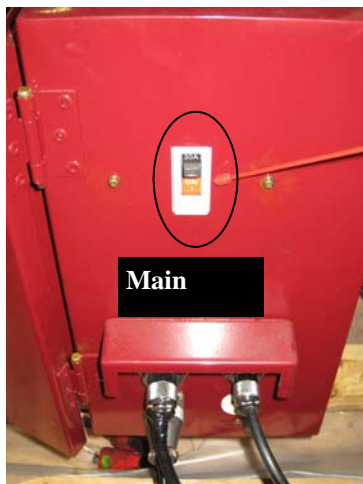

Fig. 2



Fig. 3 Tap wheel with object to make sure wheel is not cracked. The sound should be clear and consistent.



Fig. 4 Push On and Off immediately. Make sure spindle rotation is clockwise.



Fig. 5 Make sure hydraulic motor rotation is clockwise.



Fig. 6 Make sure the dust collector motor is running clockwise.



Fig. 7 Make sure the coolant pump is running clockwise.



Fig. 8 Make sure table crossfeed moving direction is correct. Function Switch on Surface Grinding Mode, Cross Feed function on Manual mode.



Fig. 9 Make sure Rapid Up/Down direction is correct. Make sure Function Switch on Rapid Mode.

If opposite direction, please turn off main power by pushing emergency button and main power switch. Switch any two power lines that go into the machine.



8. Leveling the machine

Precisely level the machine on a solid foundation. Precise leveling of the grinder is important to the finish of the product and the tolerance of the machine.

C. Levelling:

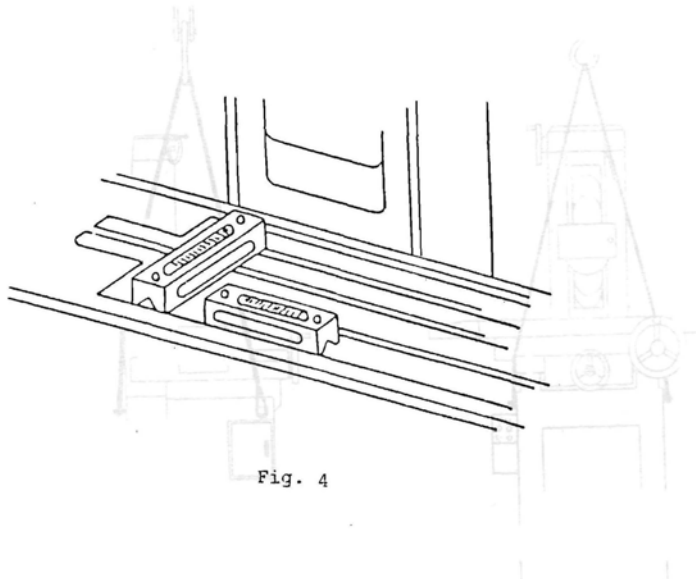

Clean the table surface thoroughly and use 2 spirit levels, one on longitudinal direction while the other one on cross direction. Adjusting the 3 levelling screws at the base till the readings is $0.02\text{mm}/1000\text{mm}$ ($0.001^{\circ}/4\text{FT}$) on both longitudinal and cross directions. Then lock the nuts on the screws and check the readings again till $0.02\text{mm}/1000\text{mm}$.

When levelling the machine, a solid floor or anti-vibration pads are highly recommended to prevent any rocking during grinding.

9. For auto lube pump, we recommend you use way oil #2 or for hydraulic oil, use Mobil DTE 25 or follow the manual suggestion.

10. Read through the operation manual and choose the correct wheel for application.

11. Ready to run your grinder: please read through the AGS-1020AHD manual to familiarize yourself with all functions, features and controls.

Should you have any questions or comments, please contact your local dealer first. They will then refer you to Acer 714-632-9701 (West Coast) or 732-752-9100 (East Coast) for further assistance.